

ORDER INFORMATION

6 2 S M A R 2 4 - F 5 G 0 W 0 1



R:PCB 90° F:Female 5:50Ω G:Gold Flash W:White

08	O RING	SILICONE	1	BLACK
07	NUT	BRASS	1	GOLD
06	LOCK WASHER	BRASS	1	GOLD
05	INSULATOR	TEFLON	1	
04	CUBE BODY	BRASS	1	GOLD
03	CENTER PIN	PHOSPHOR BRONZE	1	GOLD
02	INSULATOR	TEFLON	1	
01	BODY	BRASS	1	GOLD
NO	DESCRIPTION	MATERIAL	Q'TY	FINISH

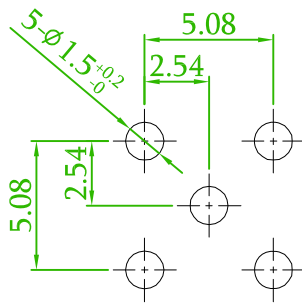
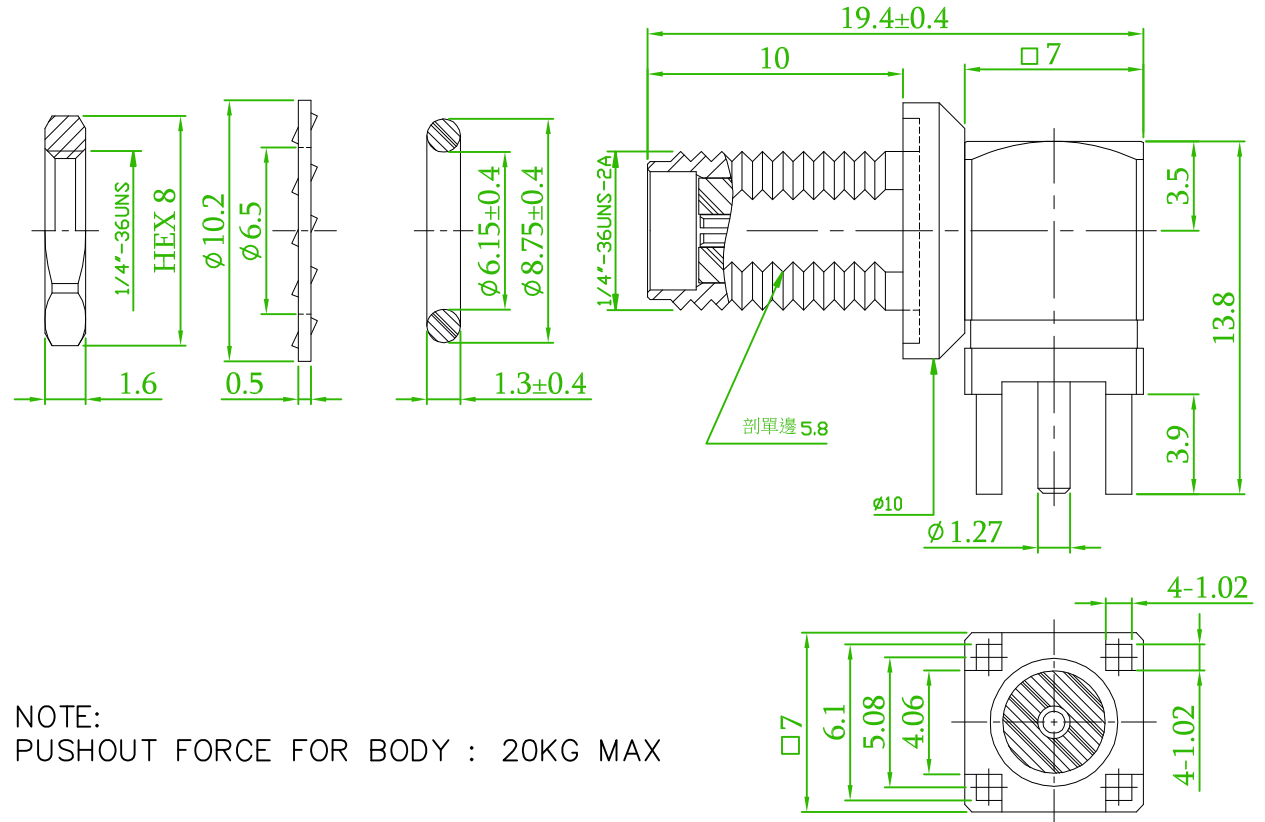

NOTE:
PUSHOUT FORCE FOR BODY : 20KG MAX

Recommended PCB Layout
(PCB TOLERANCE ±0.1)

REV.	ECN NO. OR DESCRIPTION	REVISED	DATE

<p>Amtek Technology Co., Ltd. TEL: 886-2-2260-6878 FAX: 886-2-2260-8030</p>	品名 TITLE	RF Conn				頁數 Page	1/1
	品號 PART NO.	62SMAR24-F5G0WB01				繪圖 DRAWN	Andy 2017/11/08
	圖號 DRAWING NO.	GW141-AA253	版本 REV.	A	核對 CHECKED	Jason 2017/11/08	
	客戶品號 CUSTOMER P/N		比例 SCALE	None	承認 APPROVED	Jason 2017/11/08	
	公差 TOLERANCE	.X ± 0.38 .XX ± 0.25	X° ± 3°	單位 UNIT	mm	THIRD ANGLE PROJECTION	