

REV. 更改	DESCRIPTION 說明	ENG. 修改人	APPROVE 審核

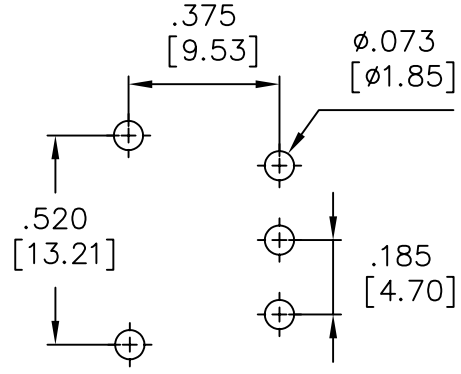
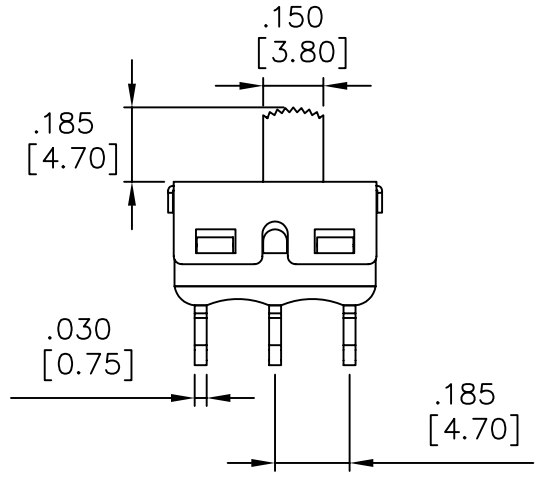
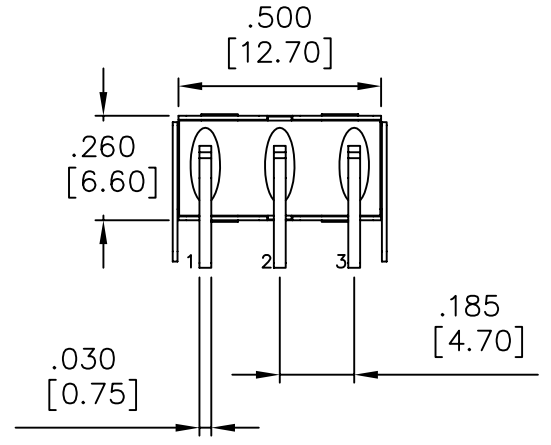
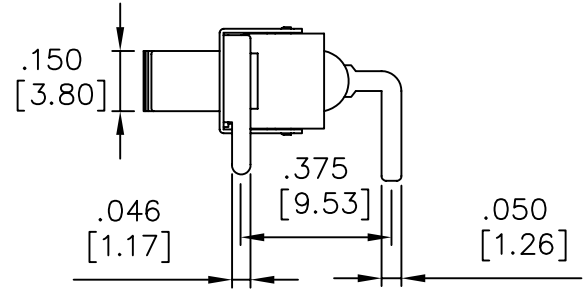
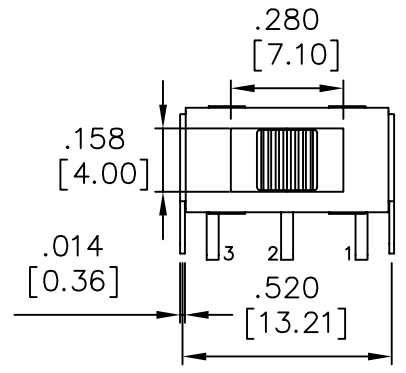

Model No.	Switching Position		
SSP-1	ON	NONE	ON
SSP-2	ON	NONE (ON)	
SSP-3	ON	OFF	ON
Term. Comm.	2-1 OPEN 2-3		

SPECIFICATIONS:

- MOVABLE CONTACT: Copper alloy, silver plated
- TERMINALS: Copper alloy, silver plated
- RATING: 5Amps with resistive load @ 120VAC or 28VDC
2Amps with resistive load @ 250VAC
- CONTACT RESISTANCE: 10m-ohms max. initial
- INSULATION RESISTANCE: 1,000M-ohms min.
- DIELECTRIC STRENGTH: 1,000V RMS @ sea level
- ELECTRICAL LIFE: 50,000 make and break cycles at full load
- OPERATING TEMPERATURE: -30°C to +85°C

ITEM NO.	500-SSP-3-S1/2M6QE
料號	5MS3S120M6QE

THESE DRAWINGS AND SPECIFICATIONS ARE THE PROPERTY OF TAIWAY ELECTRONICS LTD. AND SHALL NOT BE REPRODUCED COPIED OR USED IN ANY MANNER WITHOUT THE PRIOR WRITTEN CONSENT OF TAIWAY ELECTRONICS LTD.

UNLESS OTHERWISE SPECIFIED DIMENSIONS ARE IN MILLIMETERS ANGULAR TOLERANCE: ±1.0°

DIMENSIONS	TOLERANCE
0.00 TO 30.00mm	±0.20mm
30.01 TO 80.00mm	±0.25mm
80.01 TO 150.00mm	±0.30mm
150.01	±0.40mm

泰瑋電子有限公司
TAIWAY ELECTRONICS COMPONENTS CO.,LTD.

USED 用途	500	APPD. 審核	Amy 2009/10/06
FINISH 處理		CHKD. 校對	Amy 2009/10/06
SCALE 比例	2 / 1	DR. 製圖	Amy 2009/10/06
UNIT 單位	in(mm)		

MATERIAL	TITLE 名稱	SLIDE SWITCH	
	DWG NO. 圖號	500-SSP-3-S1/2M6QE	SIZE 圖紙
	FILE NAME 檔案名稱	5MS316QE.dwg	A4
	SHEET 張	1 / 1	REV. 更改
			1