

REV. 更改	DESCRIPTION 說明	ENG. 修改人	APPROVE 審核

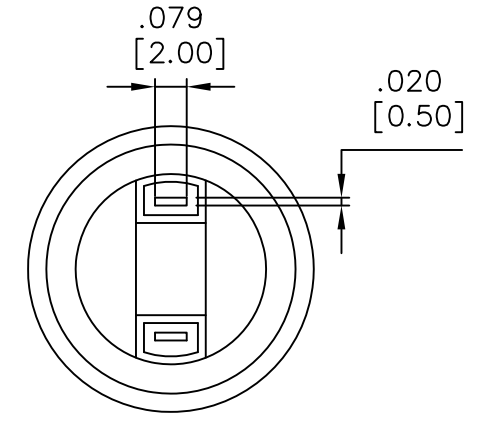
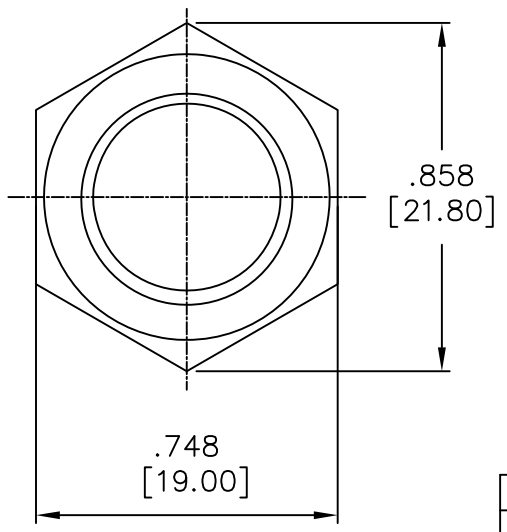
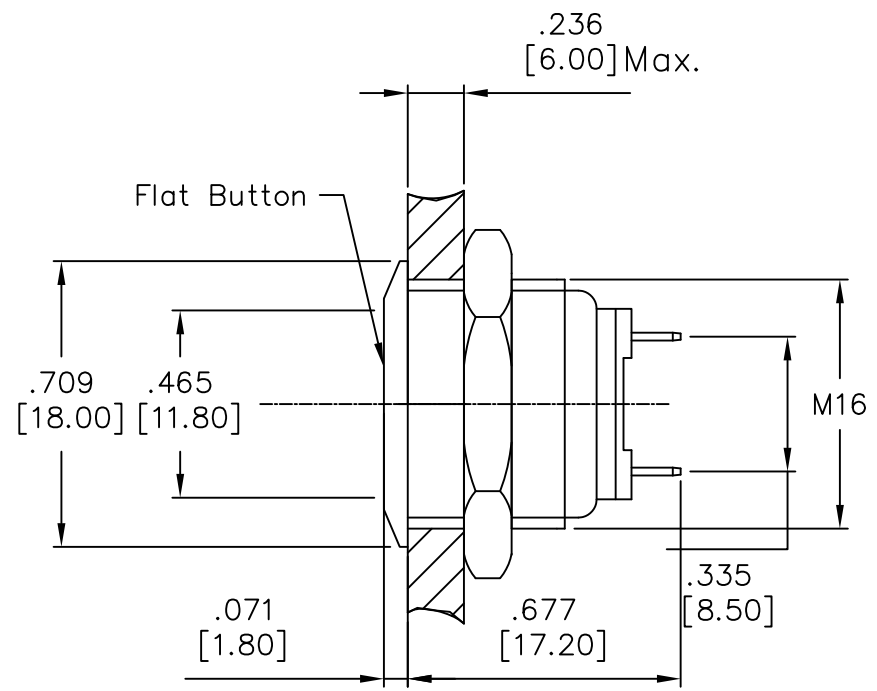

Code	Bushing & Button Material
B3	Nickel plated brass with varnished polished
B31	Gold plated brass with varnished polished
B32	Stainless steel with varnished polished

SPECIFICATIONS:

- Contact Rating: 2A @ 36VDC.
- Electrical Life: 200,000cycles.
- Contact Resistance: 50m-ohms max (initial).
- Insulation Resistance: 1,000M-ohms min @ 500VDC.
- Dielectric Strength: 2,000V RMS 50~60Hz.
- Operating Temperature: -20°C ~ +55°C.
- Switching Circuit: OFF-MOM.
- IP Class: IP65 protection.
- Torque: 5~14Nm max. applied to nut.
- Operating Force: 4N max.
- Terminal Type: Quick-connect terminal.

MATERIALS:

- Bushing & Button: Refer to above table
- Contact: Silver alloy.
- Nut: Nickel plated brass.
- Base: PBT.

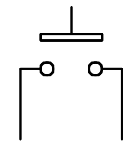

CONTACT CONFIGURATION

ITEM NO. 料號	AV01-B32-M3-F
----------------	---------------

THESE DRAWINGS AND SPECIFICATIONS ARE THE PROPERTY OF TAIWAY ELECTRONICS COMPONENTS LTD. AND SHALL NOT BE REPRODUCED COPIED OR USED IN ANY MANNER WITHOUT THE PRIOR WRITTEN CONSENT OF TAIWAY ELECTRONICS COMPONENTS LTD.

DIMENSIONS	TOLERANCE
0.00 TO 10.00mm	±0.20mm
10.01 TO 20.00mm	±0.25mm
20.01 TO 30.00mm	±0.30mm
30.01 TO 100.00mm	±0.40mm

UNLESS OTHERWISE SPECIFIED DIMENSIONS ARE IN MILLIMETERS ANGULAR TOLERANCE: ±1.0°

泰瑋電子有限公司 TAIWAY ELECTRONICS COMPONENTS CO.,LTD.			
USED 用途	AV	APPD. 審核	Amy 2007/11/29
FINISH 處理		CHKD. 校對	Amy 2007/11/29
SCALE 比例	2 / 1	UNIT 單位	in(mm)
TITLE 名稱	Anti-Vandal Switch		DR. 製圖
DWG NO. 圖號	AV01-B3(B3x)-M3-F		SIZE 圖紙
FILE NAME 檔案名稱	AV01B3M3F.DWG	SHEET 張	1 / 1
REV. 更改	1		