

REV. 更改	DESCRIPTION 說明	ENG. 修改人	APPROVE 審核

P.C.B LAND PATTERN

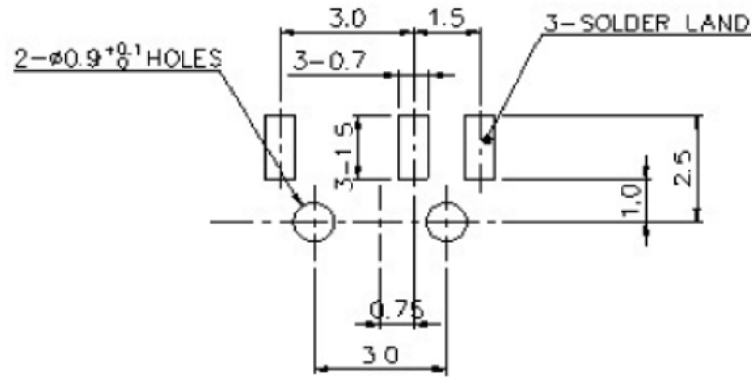

CIRCUIT DIAGRAM

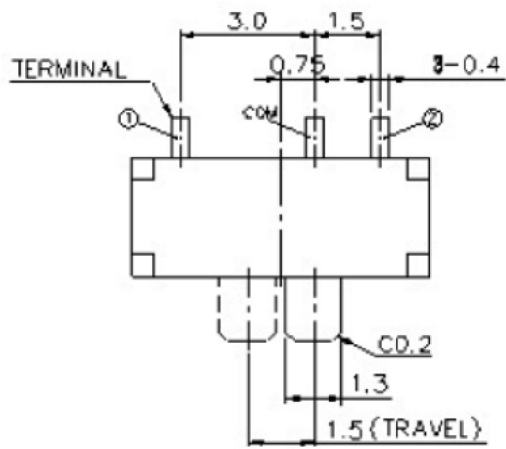
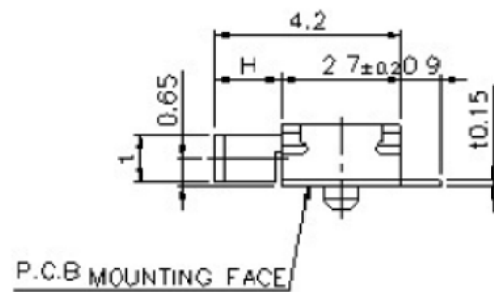
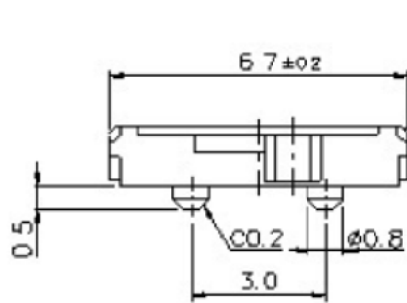
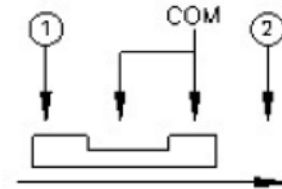

SPECIFICATIONS:

- 1.RATING: 0.3A 4VDC.
- 2.CIRCUIT: 1C-2P.
- 3.TIMING: Non-shorting.
- 4.TRAVEL: 1.5±0.10mm.
- 5.OPERATING FORCE: 150±100gf.
- 6.CONTACT RESISTANCE: 70m-ohms max.
- 7.OPERATING LIFE: 10,000 cycles.
- 8.KNOB "t": 1.1±0.10mm.
- 9.KNOB "H": 1.5±0.10mm.

THESE DRAWINGS AND SPECIFICATIONS ARE THE PROPERTY OF TAIWAY ELECTRONICS COMPONENTS LTD. AND SHALL NOT BE REPRODUCED COPIED OR USED IN ANY MANNER WITHOUT THE PRIOR WRITTEN CONSENT OF TAIWAY ELECTRONICS COMPONENTS LTD.

UNLESS OTHERWISE SPECIFIED DIMENSIONS ARE IN MILLIMETERS ANGULAR TOLERANCE: ±1.0°

DIMENSIONS	TOLERANCE
0.00 TO 10.00mm	±0.20mm
10.01 TO 20.00mm	±0.25mm
20.01 TO 30.00mm	±0.30mm
30.01 TO	±0.40mm

泰瑋電子有限公司
TAIWAY ELECTRONICS COMPONENTS CO.,LTD.

USED 用途	SS	APPD. 審核	Amy 2014/06/04
FINISH 處理		CHKD. 校對	Amy 2014/06/04
SCALE 比例	/	UNIT 單位	in(mm)
		DR. 製圖	Amy 2014/06/04

TITLE 名稱	SLIDE SWITCH		
DWG NO. 圖號	SS-1290NPA-88		SIZE 圖紙
FILE NAME 檔案名稱	SS-1290NPA-88.DWG	SHEET 張	1/1
REV. 更改	1		REV. 更改
	1		

ITEM NO. 料號	SS-1290NPA-88 YSS-1290NPA-88
----------------	---------------------------------